

RoofBLOCK™

THE MASONRY ROOF OVERHANG
BUILT TO LAST

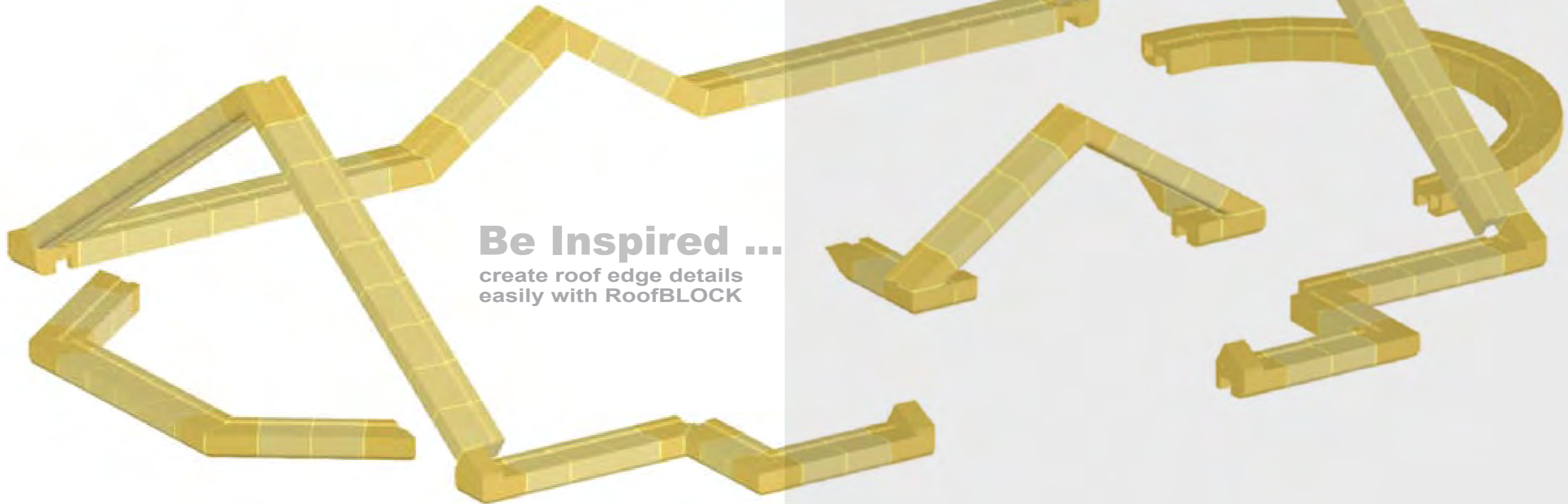

Be Inspired ...
create roof edge details
easily with RoofBLOCK



**Innovation
Award Winner**

Judges Citation: "RoofBLOCK is a significant building innovation that provides a solution to a long standing problem. It is well engineered and constructed from traditional materials with the potential for high lifecycle performance"

The Problem

Typical problems with the current timber based roof overhangs.

The roof of a building is its most important feature, but all too soon after its completion the structure begins to show signs of early deterioration due to the difficulty of its construction and the conflict between the trades involved.

In the rush to get the roof on these defects are often covered-up leaving it extremely costly in future maintenance to the owner.

Even plastic overhangs, fixed with protruding nail heads and unsightly capping pieces to a timber support which can rot unforeseen, have only a limited life as they fade and degrade in the sunlight.



Sustainability - leaving no problems for future generations



The Solution

RoofBLOCK™ provides a longer-lasting roof overhang in high quality masonry.



RoofBLOCK is a revolutionary and award-winning solution which provides an alternative to timber or uPVC fascias & soffits streamlining the construction process while providing a striking feature and functional finish. RoofBLOCK is available in a range of colours and weathers with the whole building, ensuring it looks good for years to come.

“Roofblock provides a long-lasting solution to an age-old problem and saves money by eliminating high-level roof maintenance.”

Habinteg Housing Association

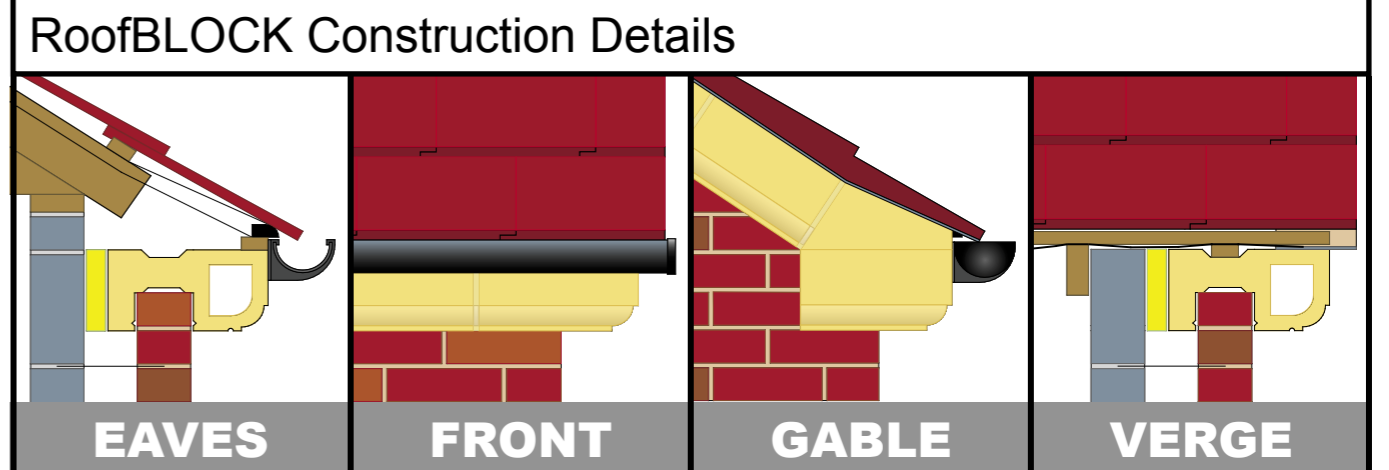

BRE Environmental

RoofBLOCK is the responsible choice

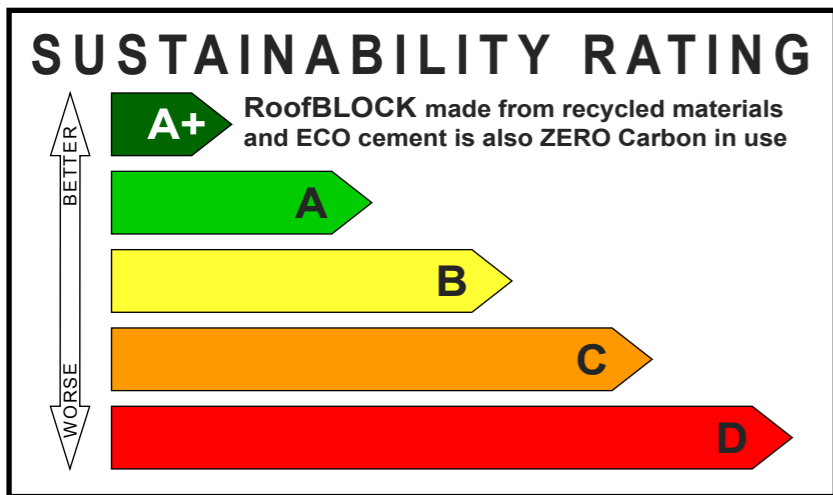

“BRE Global has assessed RoofBLOCK under the BRE Environmental Profiles scheme. The assessment concluded that RoofBLOCK achieved a similar level of environmental performance as painted timber”

With recycled content, a quality controlled production environment, long term durability and low maintenance - all benefits to the environment.

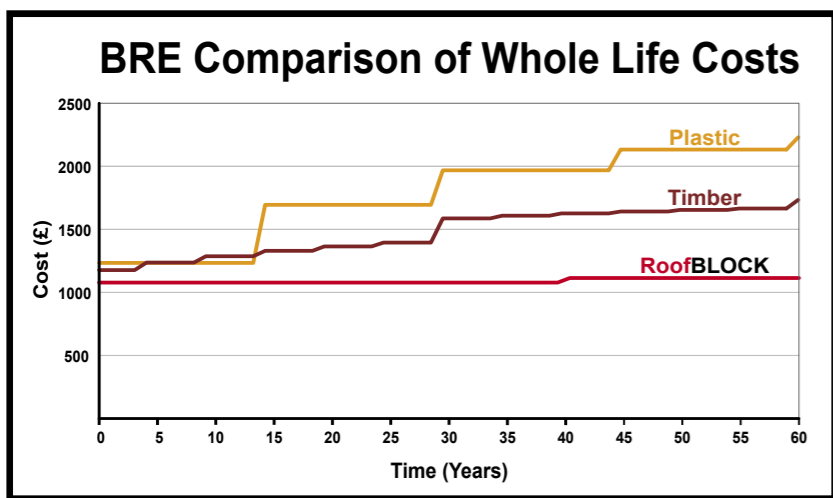

Whole Life Costing assesses the performance of construction work against other methods of achieving the same objectives not only in initial costs but also in their cost in use.

Assists clients, designers and builders in controlling long-term maintenance costs under Health & Safety CDM legislation.

RoofBLOCK saves homeowners over £10,000 in maintenance

Over the life of a building both timber and plastic boards fixed to the wooden roof structure which can also rot, will need to be constantly maintained, repaired and eventually replaced.

TIMBER		PLASTIC		RoofBLOCK	
Painting every 5yrs	£6000	Cleaning	£1500	Maintenance	NIL
Repairs	£2000	Repairs	£3000	Repairs	NIL
Renewal	£4000	Renewal	£6000	Replacement	NIL
TOTAL	£12,000	TOTAL	£10,500	TOTAL	£0

Colours & Dimensions

Bold colours and RoofBLOCK make a striking feature

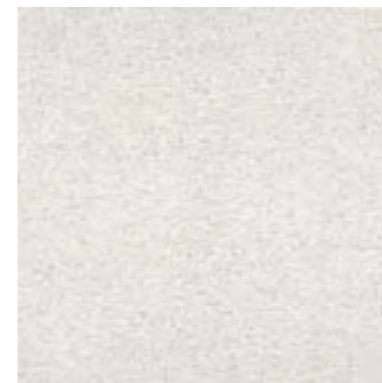

Limestone

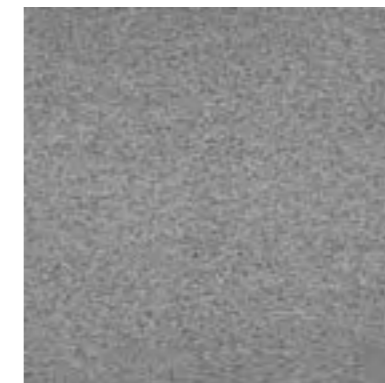

Granite

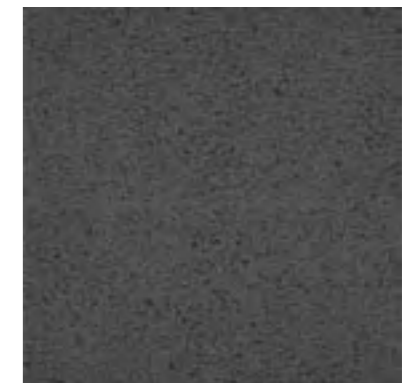

Charcoal



Bathstone



Sandstone



Yorkstone

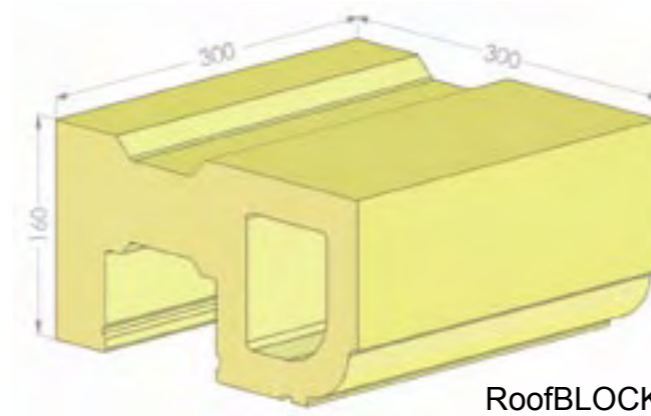

RoofBLOCK

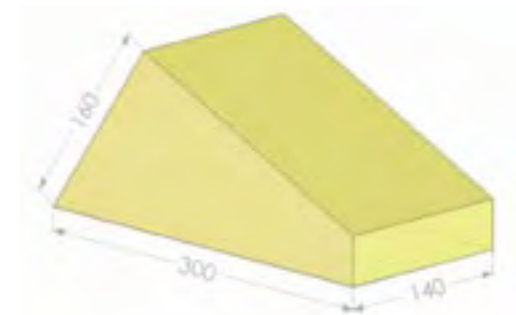

Cut Gable Block

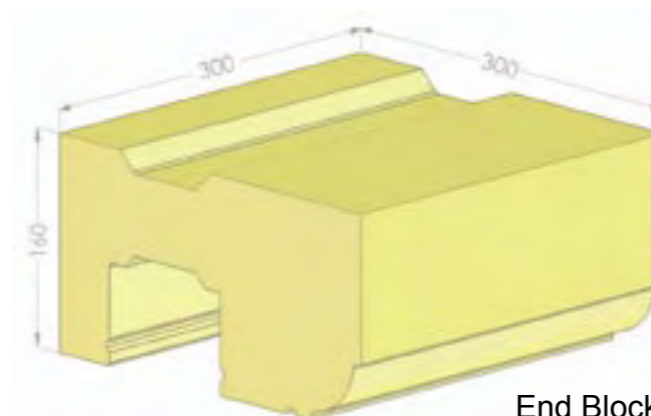

End Block

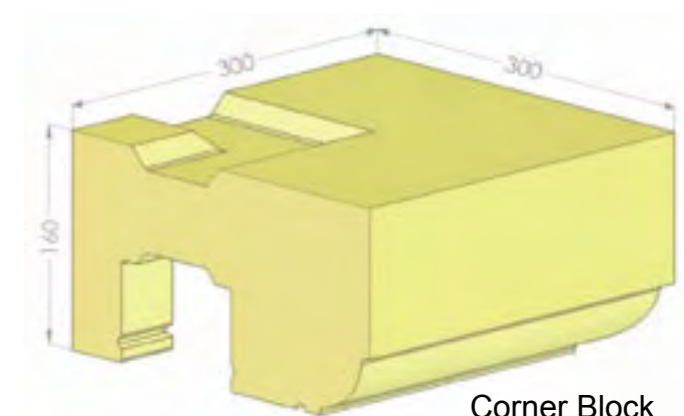

Corner Block

Installation 1

RoofBLOCK - a simple single-trade operation

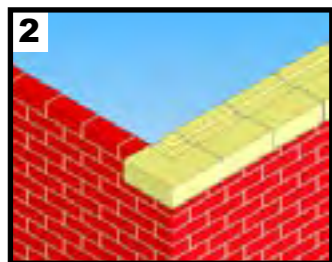
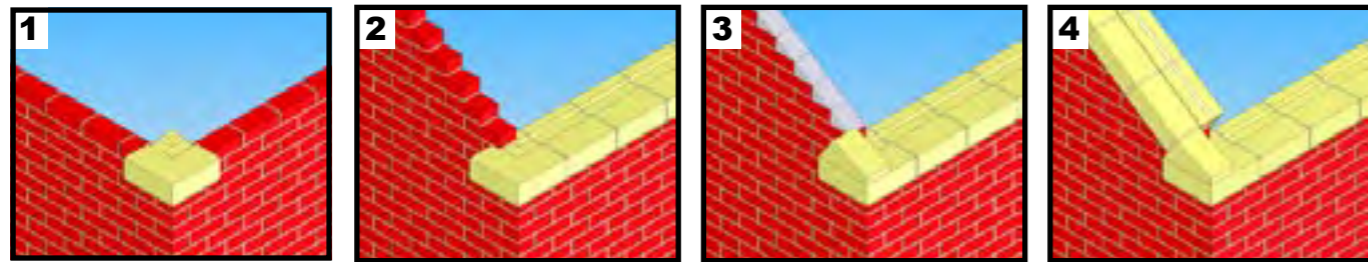

HIPPED AND GABLE CORNER CONSTRUCTION

Start the masonry overhang at the corners by bedding a Corner Block on the outside wall, then bed the RoofBLOCKs along the top of the walls with fully-filled vertical joints between the blocks.

At internal corners, simply mitre two RoofBLOCKs - this then completes the overhang for either a flat or hipped roof. (Side Pictures 1-3)

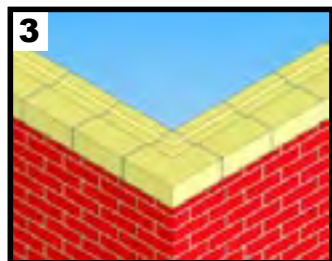

For a pitched roof, build the gable wall on top of the Corner Block and allow to set before bedding on the Gable Block cut to size. (See below)

To speed-up construction at the gables, leave the tops of the walls straight and even before bedding the overhang blocks up the slope, finishing at the peaks with plumb cut RoofBLOCKs. (Top Pictures 1-4)

“Very impressed with the RoofBLOCK system for speed of construction and ease of use.”
QMAC Construction Ltd

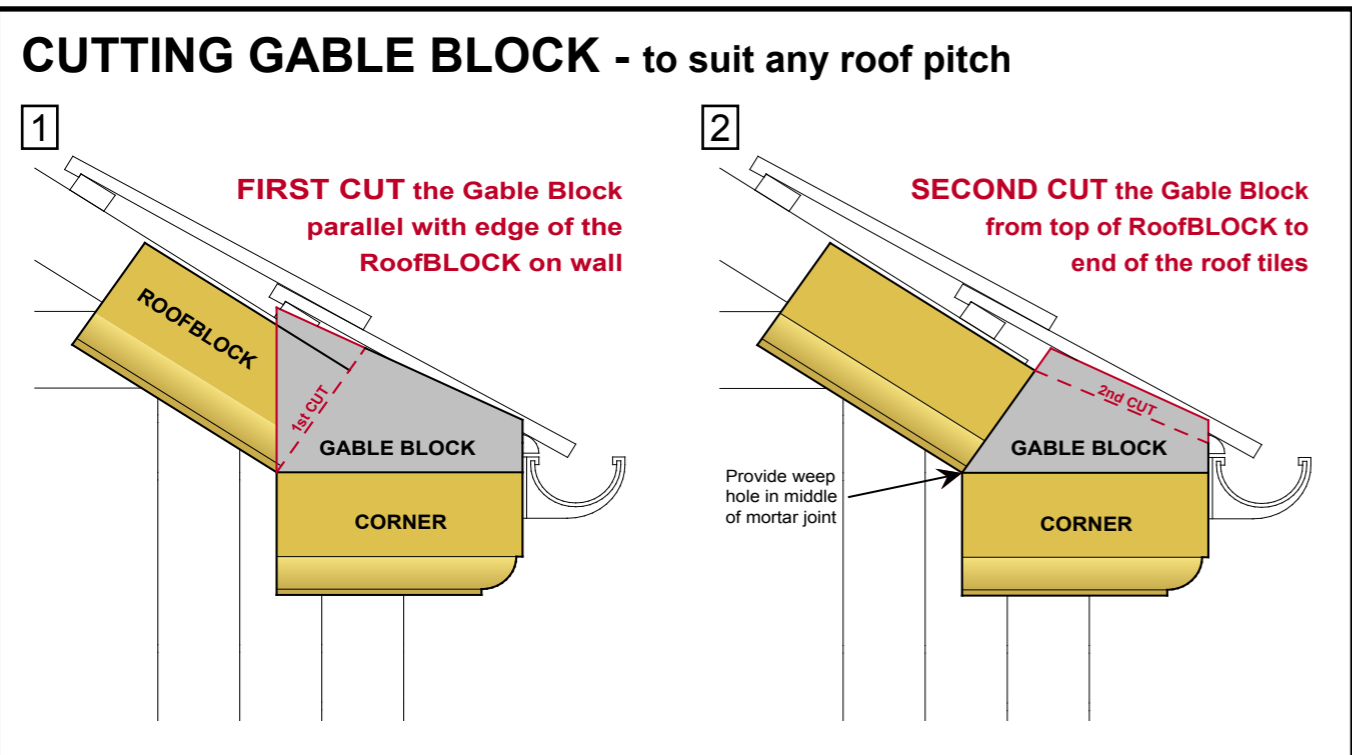

Installation 2

Working smarter with RoofBLOCK

RoofBLOCK PRODUCTIVITY SAVINGS BUILDING GABLE WALLS

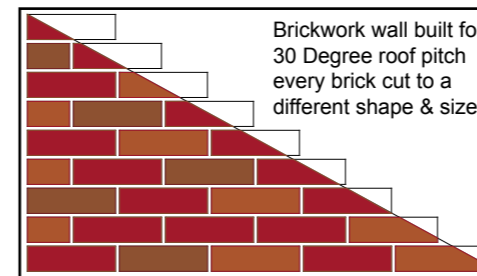

To eliminate the time consuming cutting of brick to match the roof slope, build the gable wall to follow the natural rake of brickwork, a pitch of 1:1½ (i.e. 33.7°).

The brick deep recess in the base of the RoofBLOCK will hide the ragged top of the brickwork slope whilst left over blockwork & mortar can be used-up to smooth out the brickwork steps before laying RoofBLOCKs up the gables.

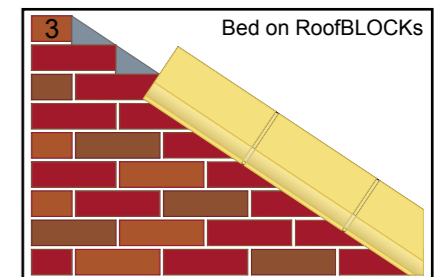
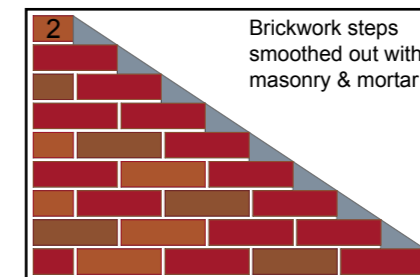
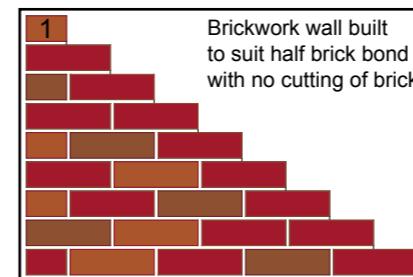

“RoofBLOCK costs were comparable with traditional eaves construction”
Donaldson Associates, Quantity Surveyors

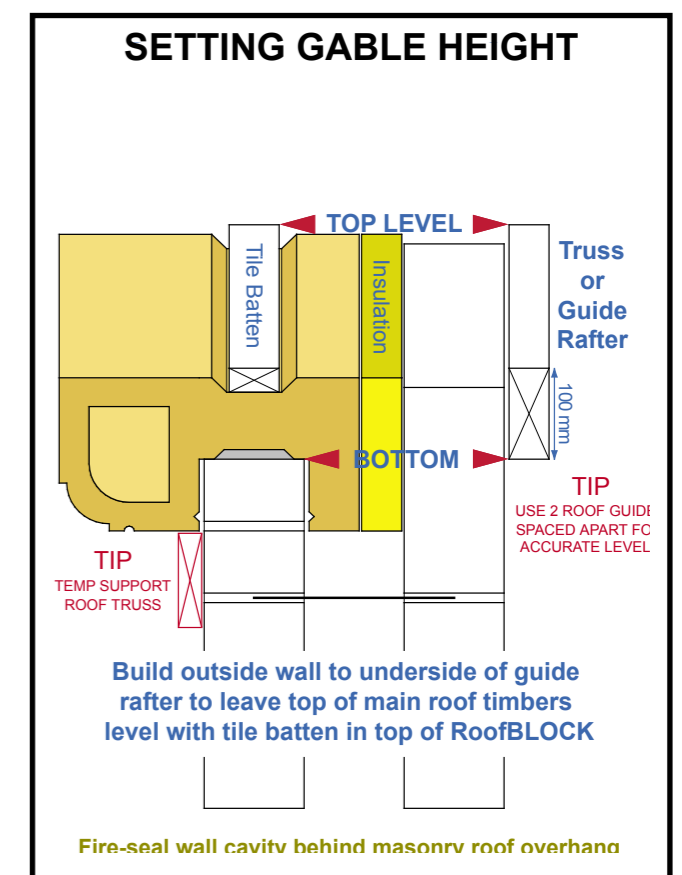
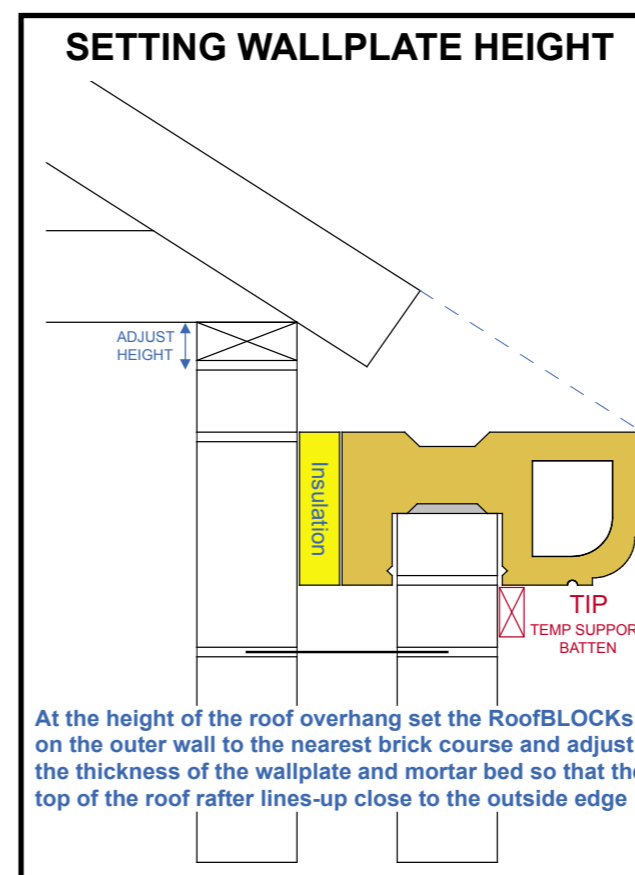

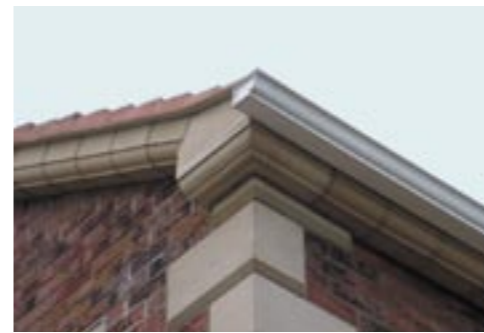

RoofBLOCK has been used throughout UK & Ireland on a wide range of projects from commercial buildings to housing association projects, residential developments to one-off self build projects.

**RoofBLOCK can easily
create inspiring details ...**

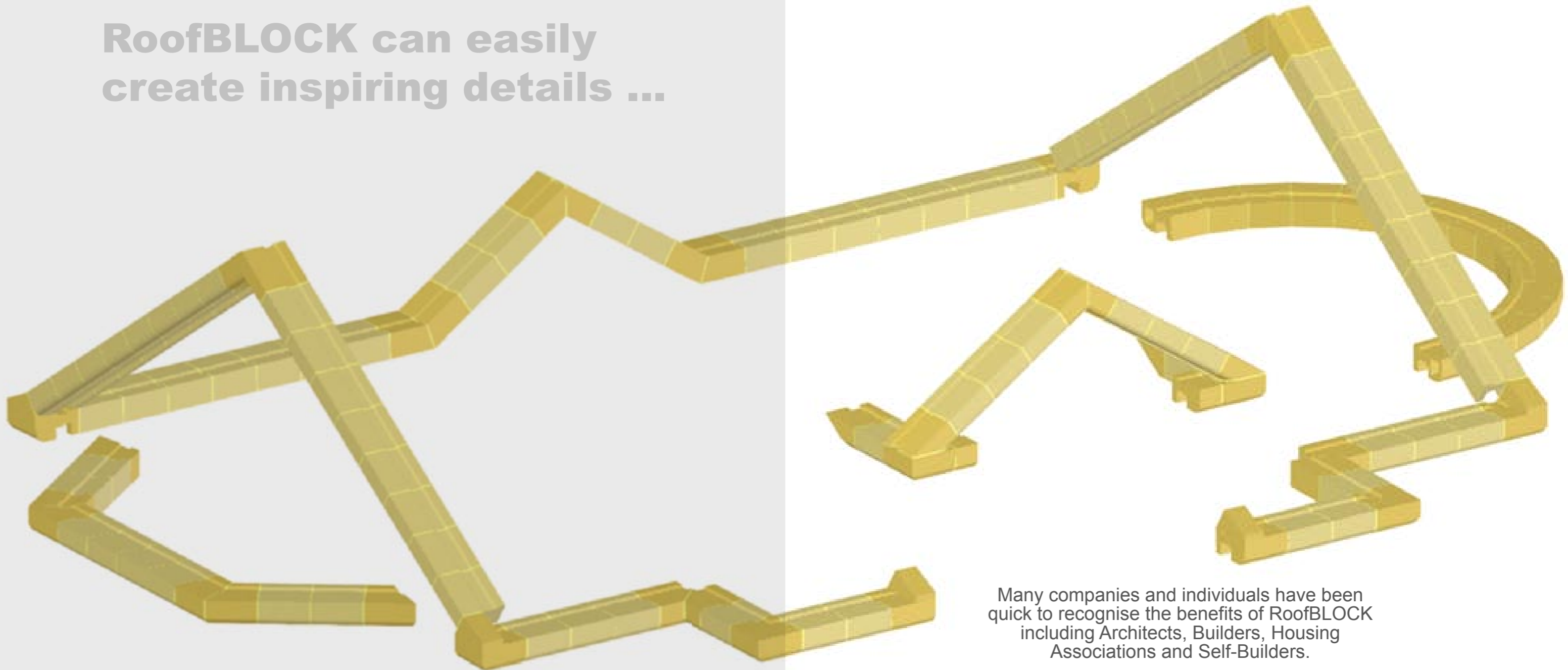

Many companies and individuals have been quick to recognise the benefits of RoofBLOCK including Architects, Builders, Housing Associations and Self-Builders.

Send your plans for a FREE estimate or find out more by contacting us...



Lignacite Limited

High Street, Brandon IP27 0AX

Tel 01842 810678

Fax 01842 814602

info@lignacite.co.uk www.lignacite.co.uk

